

Eliminate Long Lead Times

Diba's line of standard probes are ideal for OEMs and engineers interested in high quality, quick-turnaround components that can speed up the design phase of projects and shorten the lead time normally associated with manufacturing custom probes. Device makers will also benefit by improved supply chain management, as Diba's standard probes are in stock and ready to ship. Diba standard probes offer these features:

- 316 stainless steel construction for performance and durability
- Easily connects to Diba tubing assemblies with the use of a flare or a ferrule
- Increased dispense accuracy and minimized internal diameter (ID) roughness with a drawn reduced diameter tip
- 200 micro liter internal volume capacity
- 5.9 inch stroke length, capable of reaching the bottom of most sample tubes
- Additional carryover reduction can be achieved with fluoropolymer-based coatings on the outside diameter (OD) which is available upon request as a special order

Standard Probe Types

Drawn

Drawn probes feature a reduced diameter tip. The tip of the probe is reduced by a draw down process which ensures that the surface finish of the reduced section remains smooth once the process is completed.

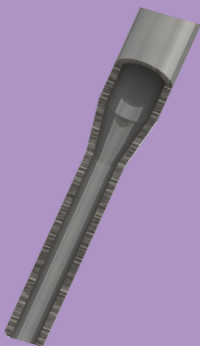

DP3 Polished

DP3 is Diba's proprietary polishing process which minimizes carryover by reducing ID roughness by a factor of 3 to 5. DP3 technology also improves wash characteristics and provides added durability.

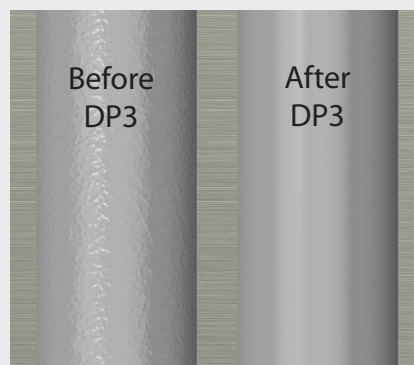

FEP Lined

FEP lined probes are made of 316 stainless steel and are lined with FEP tubing. FEP lined probes offer an unbroken fluid path with no joints back to the pump.

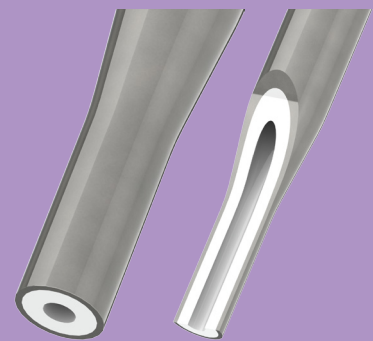

Regular Drawn Standard Probe DB200-14954

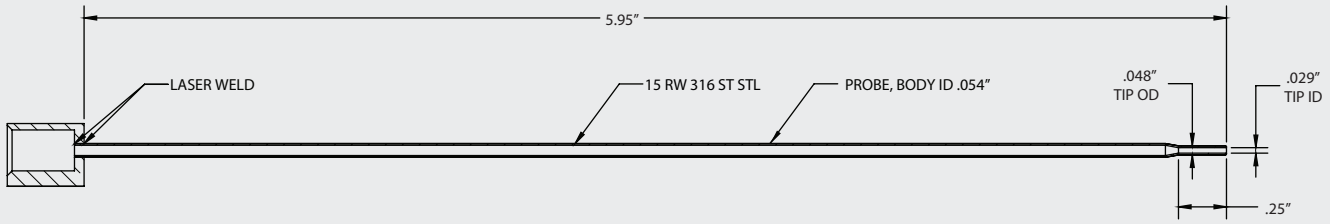

DP3 Polished Drawn Standard Probe DB200-14953

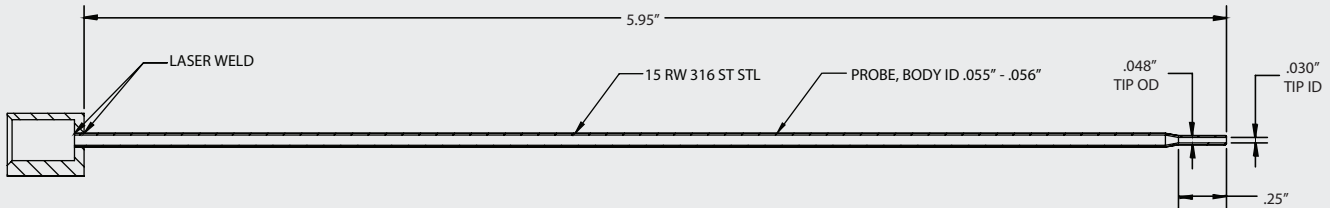

FEP Lined Standard Probe DB200-14952

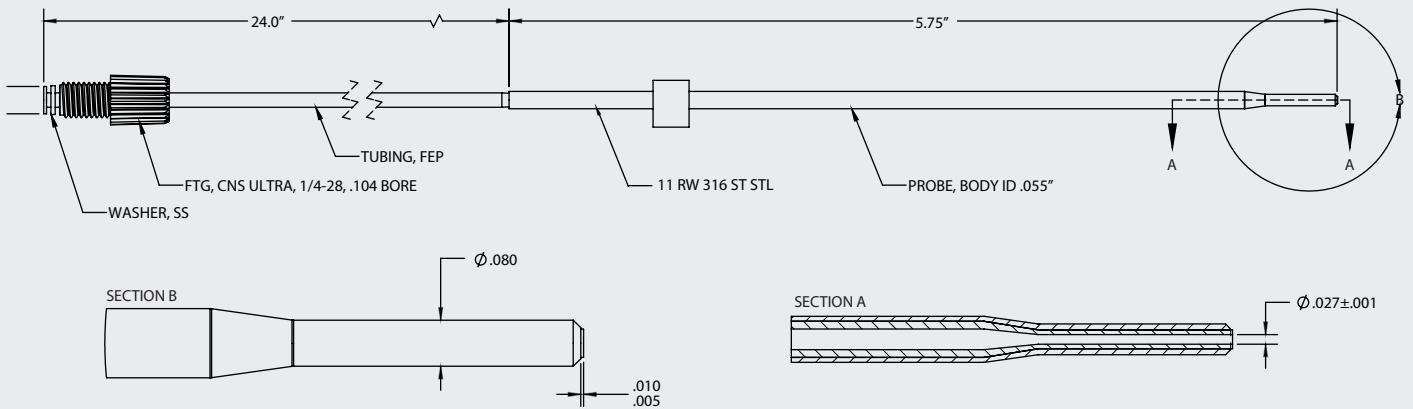

Standard Probes Ordering Information

PROBE TYPE	PART NUMBER	MATERIAL	PROBE BODY ID	VOLUME	RMS
Regular Drawn Standard Probe	DB200-14954	316 ST STL	.054"	200 µl	20+
DP3 Polished Drawn Standard Probe	DB200-14953	316 ST STL	.055" - .056"	200 µl	4+
FEP Lined Standard Probe	DB200-14952	316 ST STL	.055"	200 µl	N/A

Diba Worldwide

North America
 Diba Industries Inc.
 4 Precision Road
 Danbury, CT 06810 USA
 Tel: +1 (203)-744-0773
 Fax: +1 (203)-744-0663
 salesdept@dibaind.com

Europe
 Diba Industries Ltd.
 2 College Park
 Coldhams Lane
 Cambridge, CB1 3HD, UK
 Tel: +44 (0) 1223 472801
 Fax: +44 (0) 1223 416787
 sales@dibaind.com

China
 Diba Industries Inc.
 Halma International Ltd.
 Shanghai Representative Office
 Room 1106, Metro Plaza, No 555
 Lou Shan Guan Road,
 Shanghai, PRC 200051, CHINA
 Tel: +86-21-6016-7622
 Fax: +86-21-5206-8191
 chinasales@dibaind.com

www.dibaind.com
 A HALMA COMPANY